

# Engineered Solutions – from Laboratory to Trusted Global Nuclear Industry Advisor

– skillfulness and communication

April 23, 2014

ENGINEERED SOLUTIONS FOR DEMANDING ENVIRONMENTS®

**Technetics**  
GROUP

EnPro Industries companies

**EN • KO**  
2014

# TECHNETICS IN THE NUCLEAR CYCLE

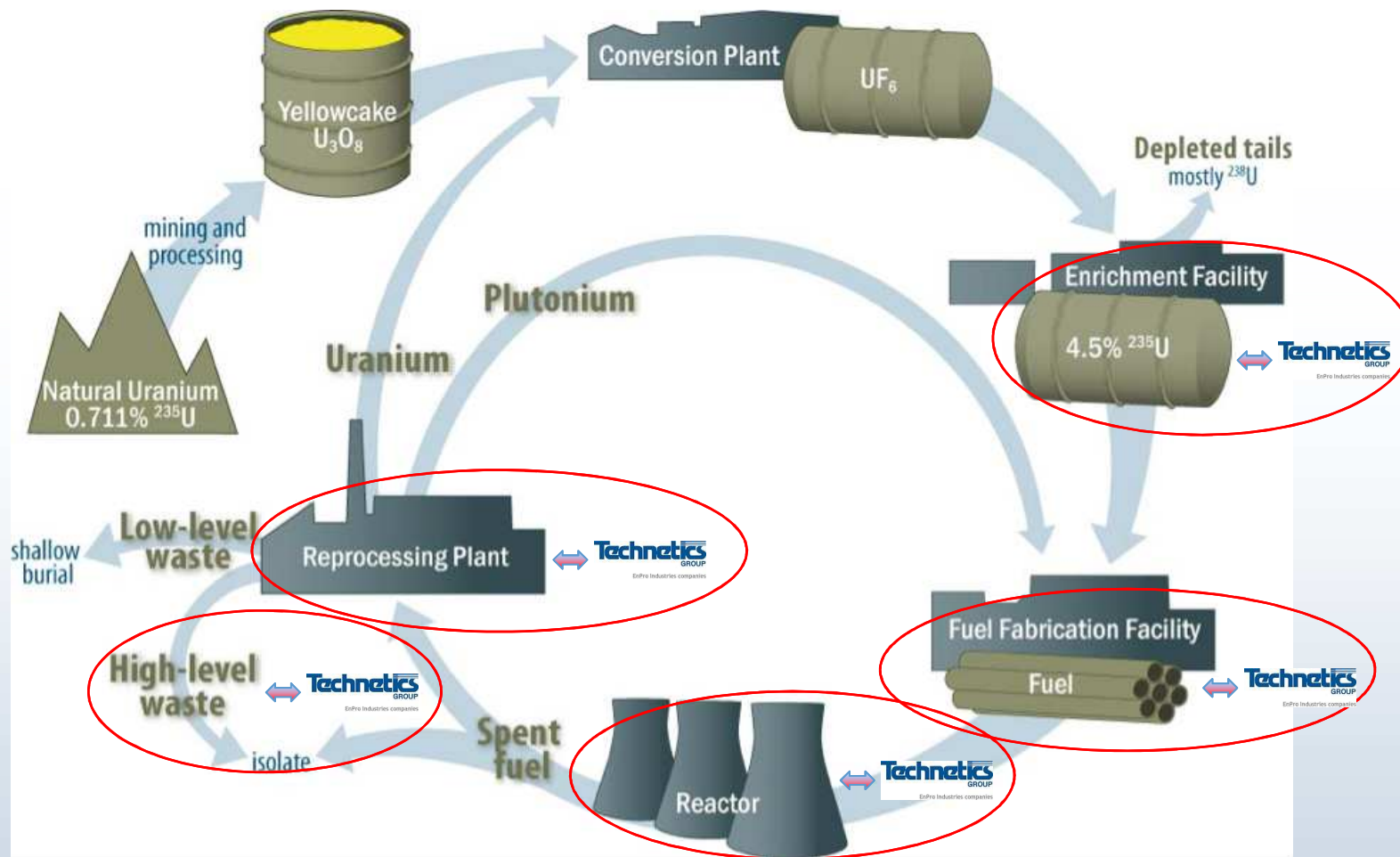

# Seals in Nuclear Power Generation

## History of Technology and Skills Development



In the nuclear power industry,  
there's no such thing as "off the shelf"

At Technetics Group, our seals, components and subsystems are custom-engineered to your precise specifications. Our engineers work with you, adhering to your component designs with peerless attention to detail.

- **France, 1970-ies:**  
independant nuclear fleet and cycle  
– enrichment: the start-off
- **Task:**  
investigate principal & essential parameters  
→ what is leak tightness?
- **Result: metal-to-metal sealing concept to separate two functions:**
  - rigidity of mechanical joint
  - elasticity and plasticity for sealing performance
- **Intergated cooperation**
  - with **CEA** from very beginning
  - nuclear industry & utilities & NRA



# Seals in Nuclear Power Generation: small components – HIGH SAFETY IMPACT



In the nuclear power industry,  
there's no such thing as "off the shelf"

At Technetics Group, our seals, components and subsystems are custom-engineered to your precise specifications. Our engineers work with you, adhering to your component designs with peerless attention to detail.

range of metal-to-metal sealing products



E-FLEX™



ORIGRAF®  
Graphite Seals



CEFILAIR®



BELFAB® Bellows



QDS  
Quick Disconnect System



Abradable Seals



Brush Seals



Polymer  
Machined Components



PEEK Shapes  
and Component



# Metal to Metal Concept

- Optimum compression
- Low elastic solicitation
- Rigidity of the assembly
- Thermal & Pressure transients

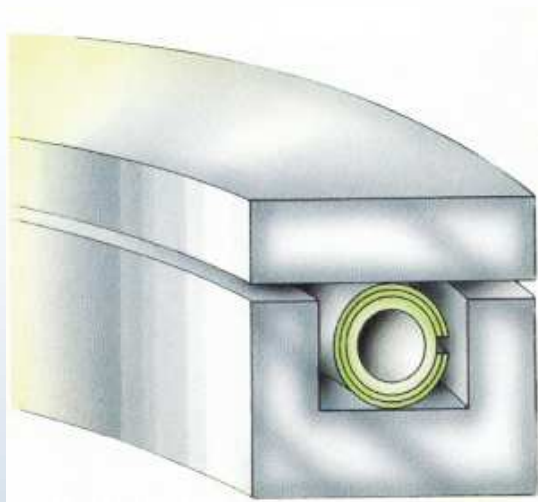

Before Tightening

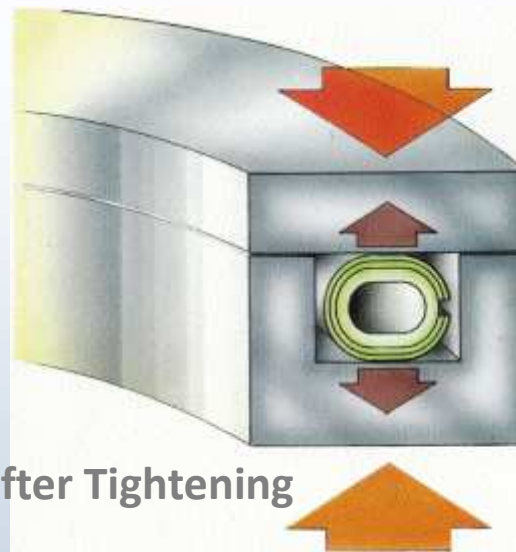

After Tightening

# Metal to Metal Concept

- Optimum compression
- Low elastic solicitation
- Rigidity of the assembly
- Thermal & Pressure transients

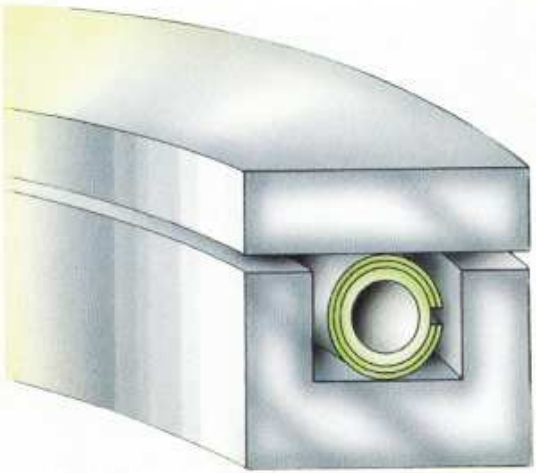
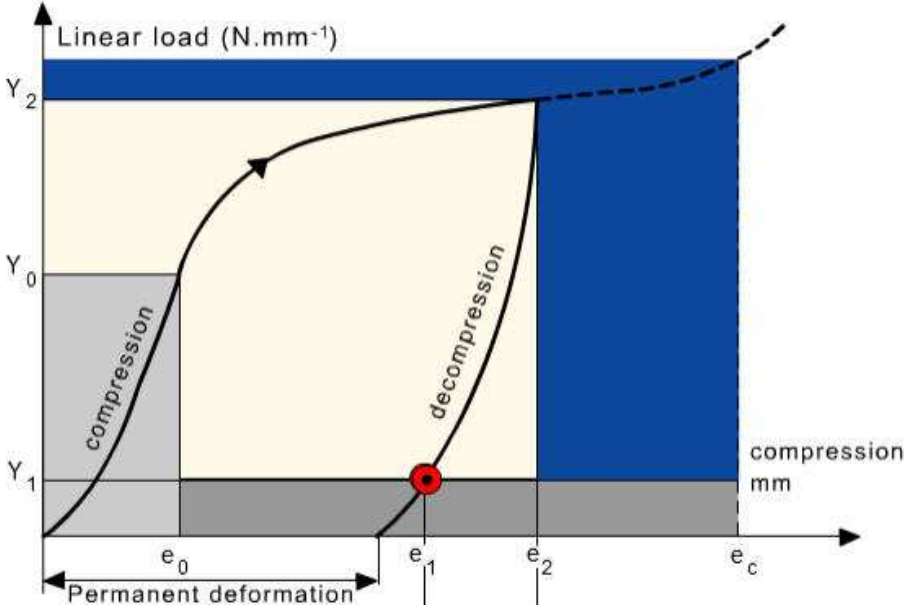

Before Tightening

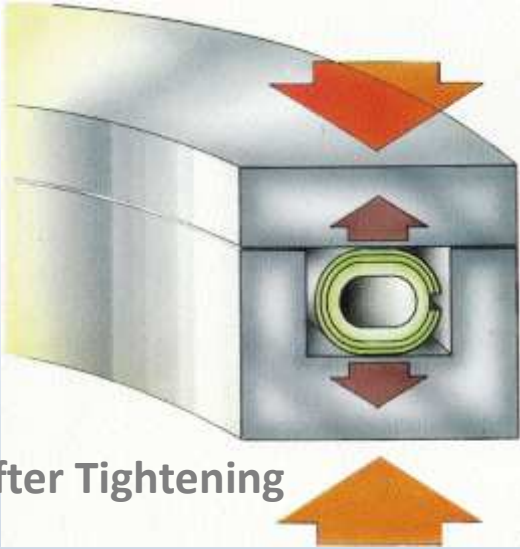

After Tightening

useful elastic  
resiliency:  
engineered  
to meet  
application  
requirements

# URANIUM ENRICHMENT

## Eurodif plant and GB2 plant

- First application of Helicoflex<sup>®</sup> designed by the Fluid Sealing Laboratory in collaboration with the C.E.A.
- UF<sub>6</sub> at 150-200°C
- Helicoflex<sup>®</sup>
- Elastomers

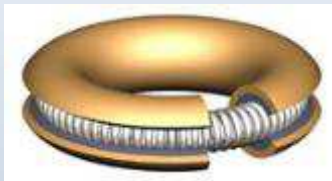



# NPP: Nuclear Sealing Solutions



sales@techneticsgroup.com  
techneticsgroup.com

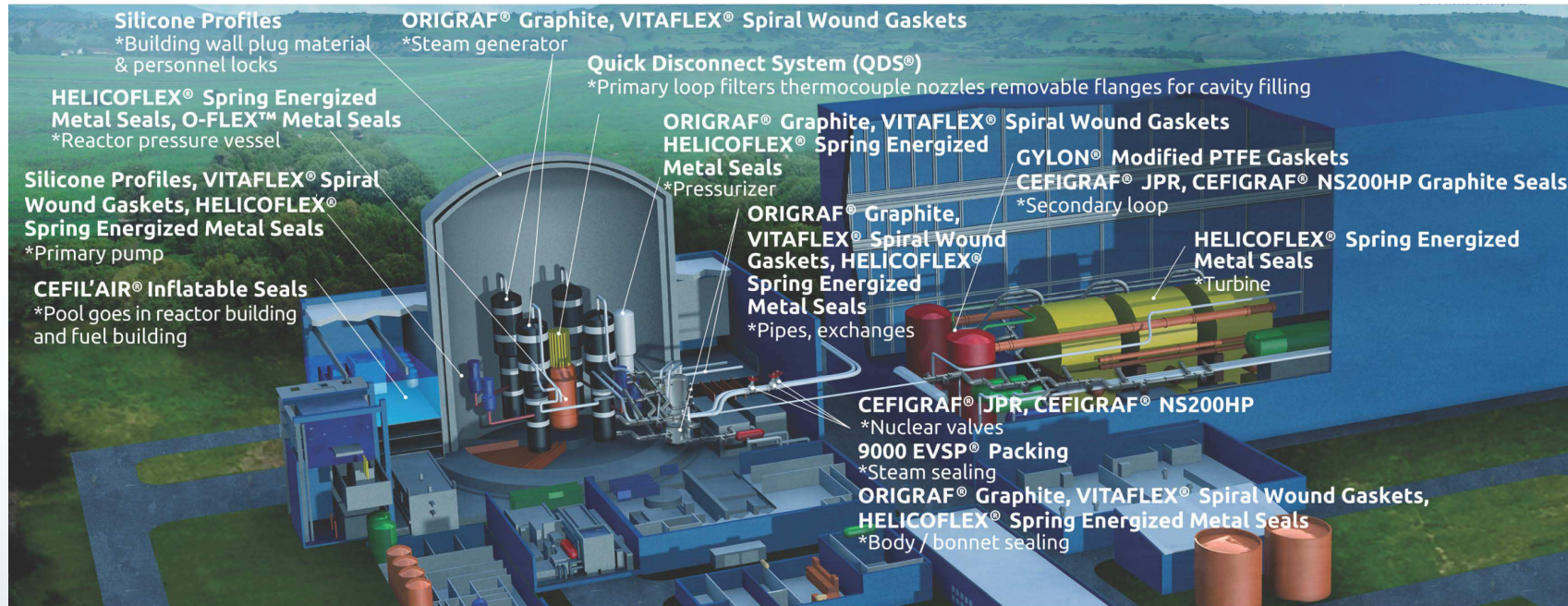

GYLON® IS A REGISTERED TRADEMARK OF THE GARLOCK FAMILY OF COMPANIES

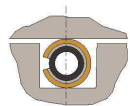

HELICOFLEX® SEALS



DELTA® SEALS

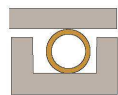

O-FLEX™ SEALS



CEFIGRAF® GRAPHITE



ORIGRAF® GRAPHITE



QDS®

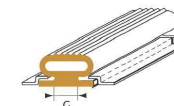

CEFIL'AIR® INFLATABLE SEALS



VITAFLEX® SPIRAL WOUND GASKETS



# NPP: REACTORS



## Reactor pressure vessels :

- PWR, BWR, EPR™
- prototype reactors
- 155 bar at 320°C

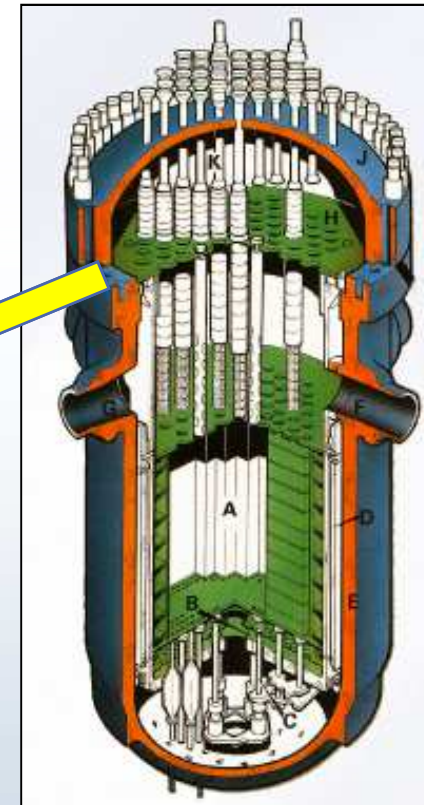
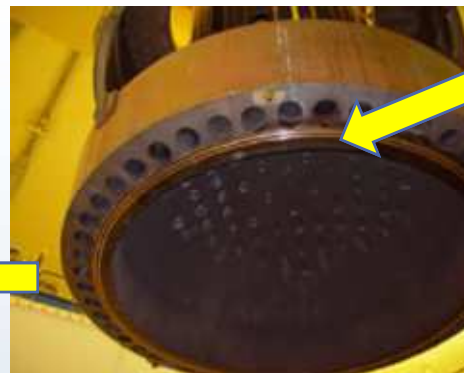

# NPP: REACTORS



## Reactor pressure vessels :

- Helicoflex<sup>®</sup> configuration (France, Europe, China, Japan...)
- O-Flex<sup>™</sup> configuration (USA, China, Japan, Korea, ...)
- 1,0 m to 7,3 m diameter (CS 12,7 mm)

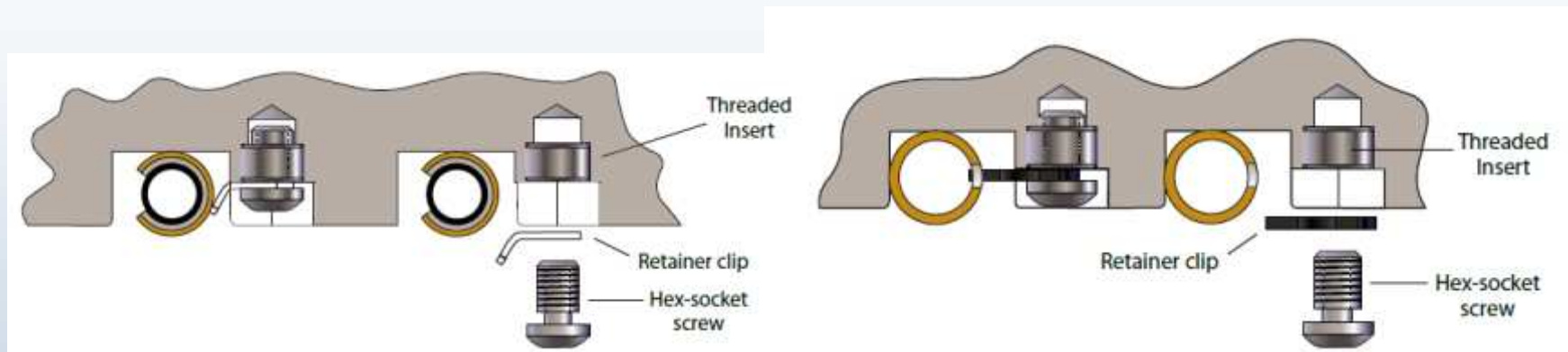
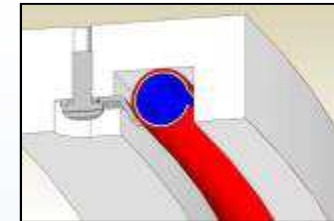

# NPP: NSSS COMPONENTS

- steam generators
- pressurizers
- primary pumps
- Boric acid injection tanks
- pipings

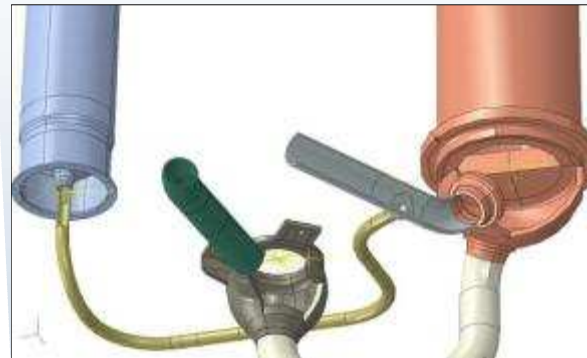



# NPP: REACTOR AND FUEL BUILDINGS



- pool gate inflatable seals (SBR)
- wall plugs and personnel locks (silicone)
- thermocouple nozzles (QDS, Helicoflex®)

## SERVICE CONDITIONS :

$\Delta P = 1 \text{ bar}$   
 $T = 40-80 \text{ }^\circ\text{C}$   
Radioactive demineralized water  
Life time = 5 years

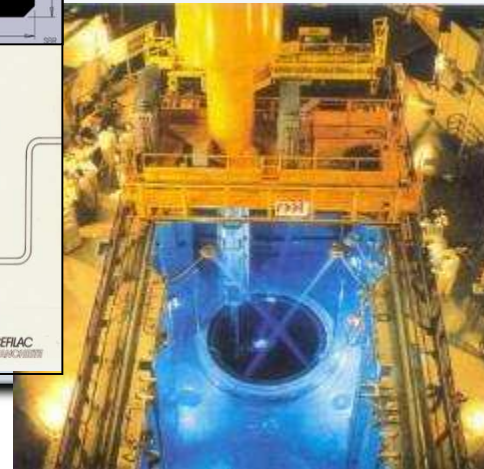
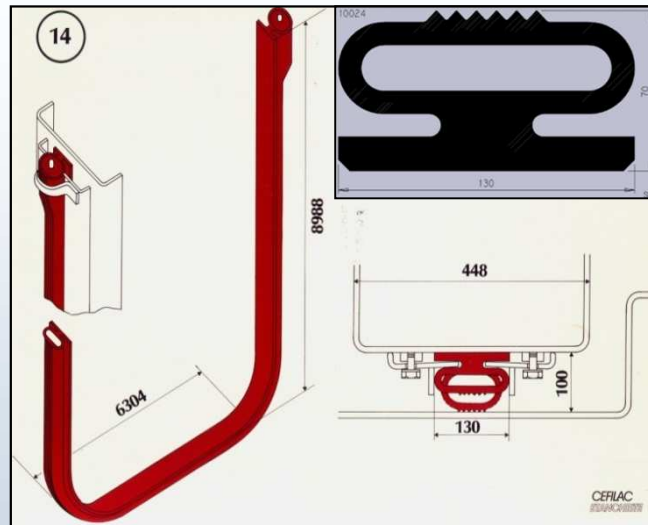

# REPROCESSING AND STORAGE

- AREVA NC reprocessing plant
- reprocessing research
- **containers** for transportation & storage  
(300-years math. simulation ongoing)



# REPROCESSING AND STORAGE

- Helicoflex<sup>®</sup> with double seal
- Aluminium/Silver
- Elastomers

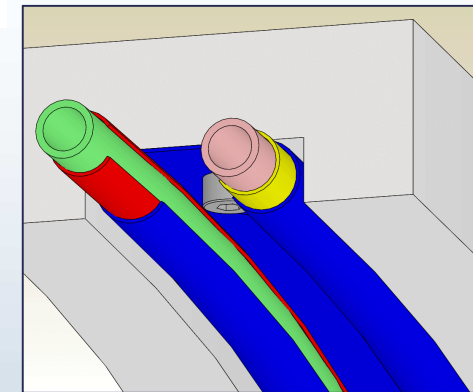
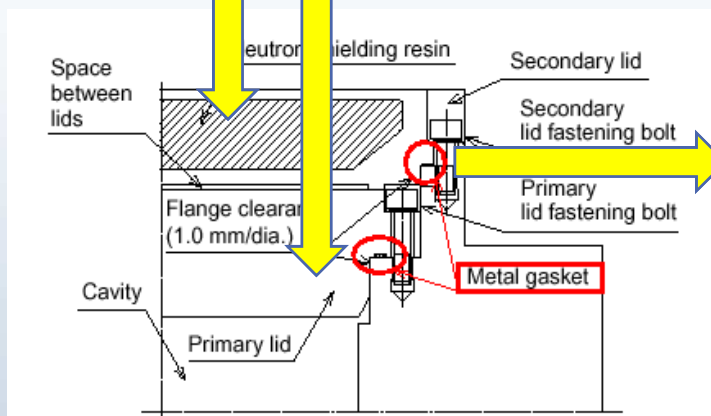
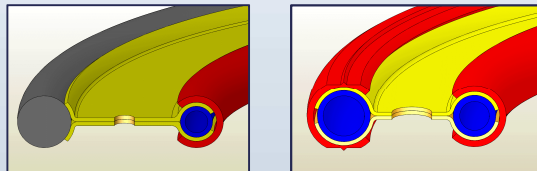
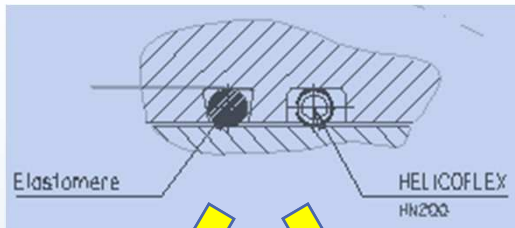
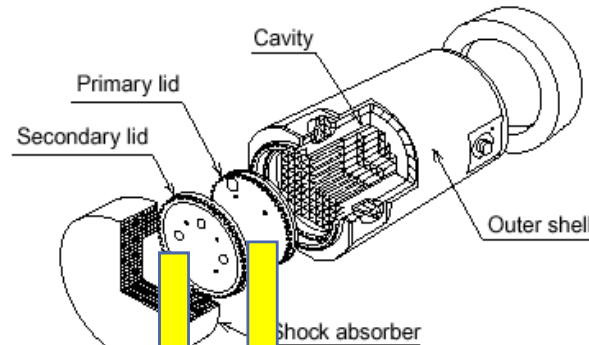
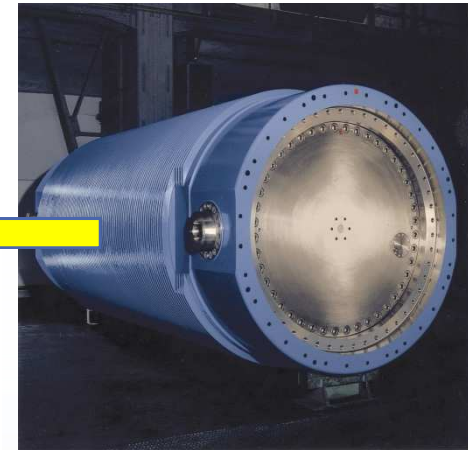



# NEW PWR REACTORS: EPR, AP1000



- reactor pressure vessel
- pressurizers & steam generators
- primary pumps
- pipings and diaphragms
- exchangers
- valves
- turbines
- filters

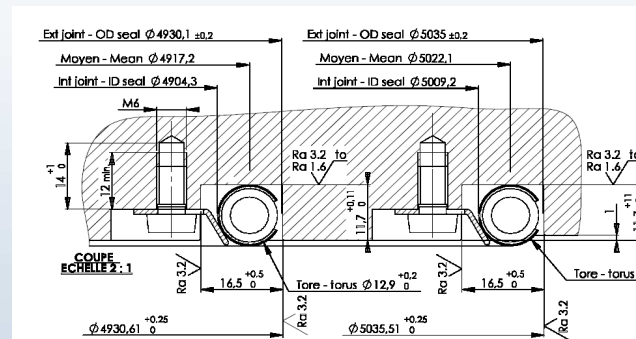
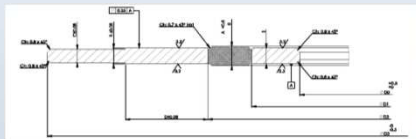

# RESEARCH REACTORS

PBMR Peddle Bed Modular Reactor

RJH Reactor Jules Horowitz

ASTRID

Advanced Sodium Technological Reactor for Industrial Demonstration

HTR (INET) High Temperature Reactor

Helium Cooled Reactor

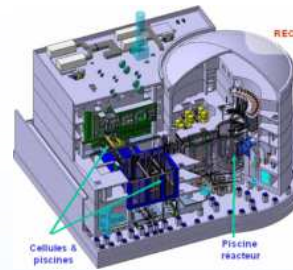
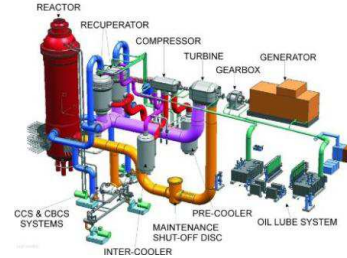

Le RJH  
REACTEUR DE  
RECHERCHE EUROPEEN  
100MW

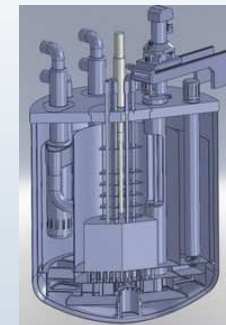
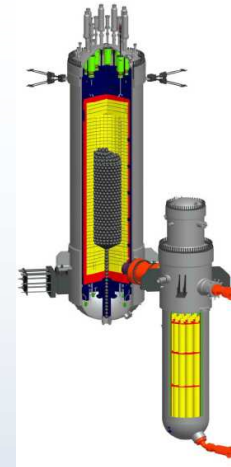

# FUSION REACTORS

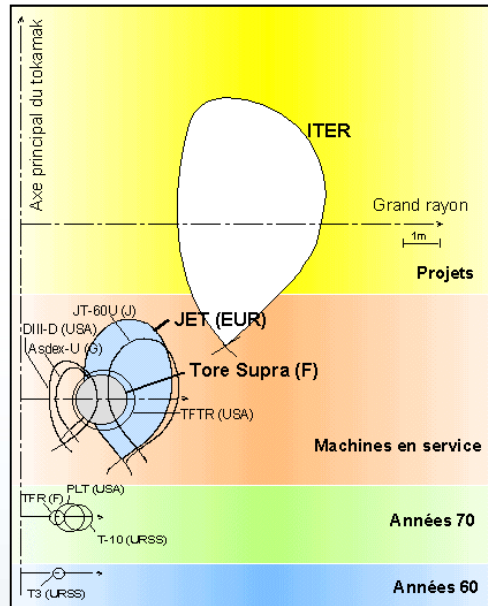

## Tokamak Fusion Test Reactors :

- TFTR, JET, Tore Supra
- C-Mod, FTU, ATF
- K-Star, ITER

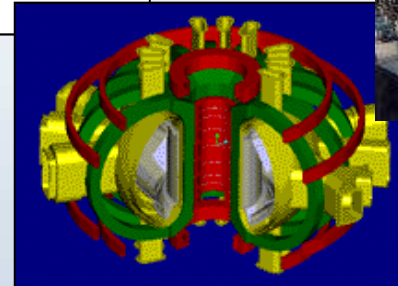
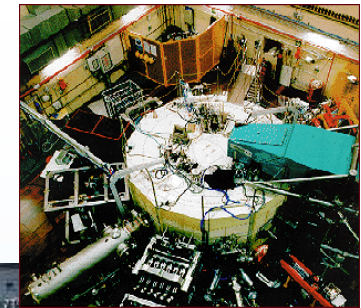



# FUSION REACTORS : ITER

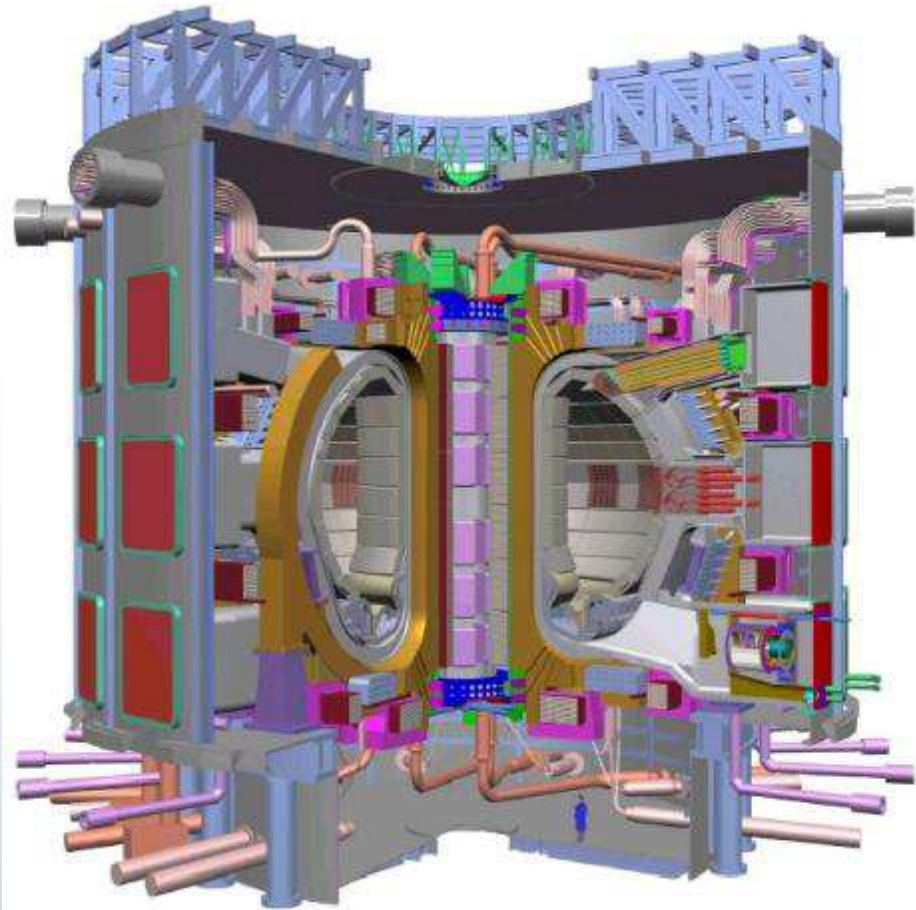

## ITER

- Worldwide Project
- Based in France
- Design stage
- Timing 2010-2030+

# FUSION REACTORS : ITER

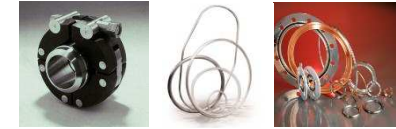

- Finite Element Analysis (FEA)

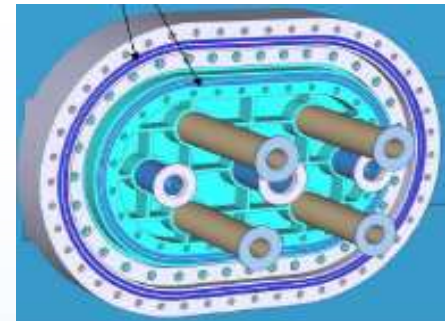
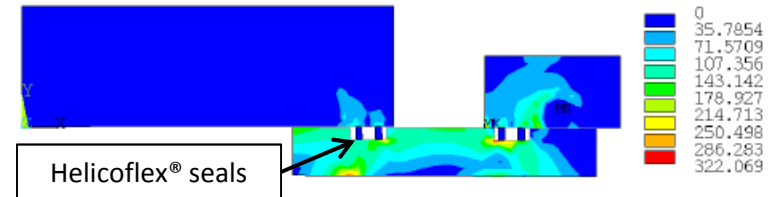
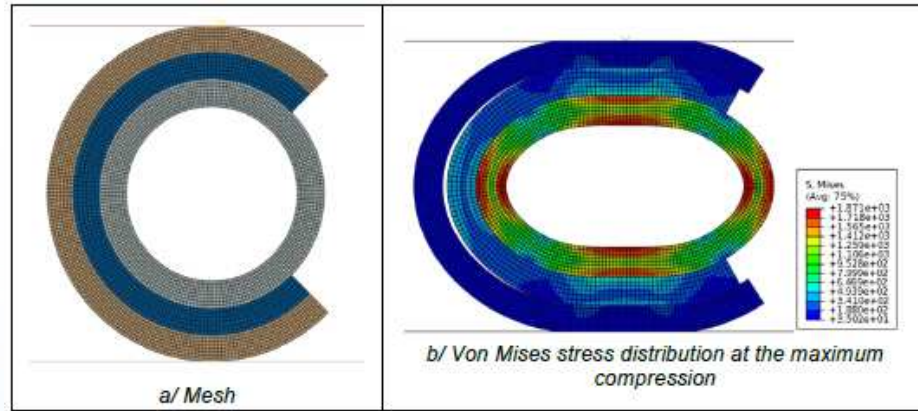

- Vacuum Flanges Design, Validation, Testing

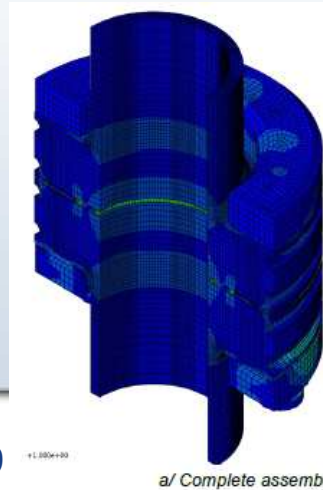

Stress intensity (MPa)

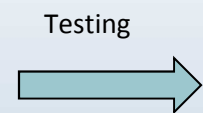
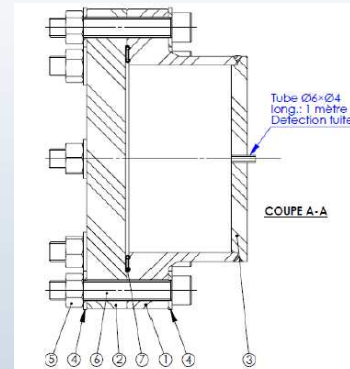
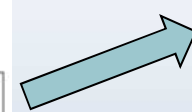

# FUSION REACTORS : ITER



Collaboration of CEA Cadarache & Technetics France  
large double seals

- flanges 2200 x 2600 mm
- flanges 1200 x 1200 mm

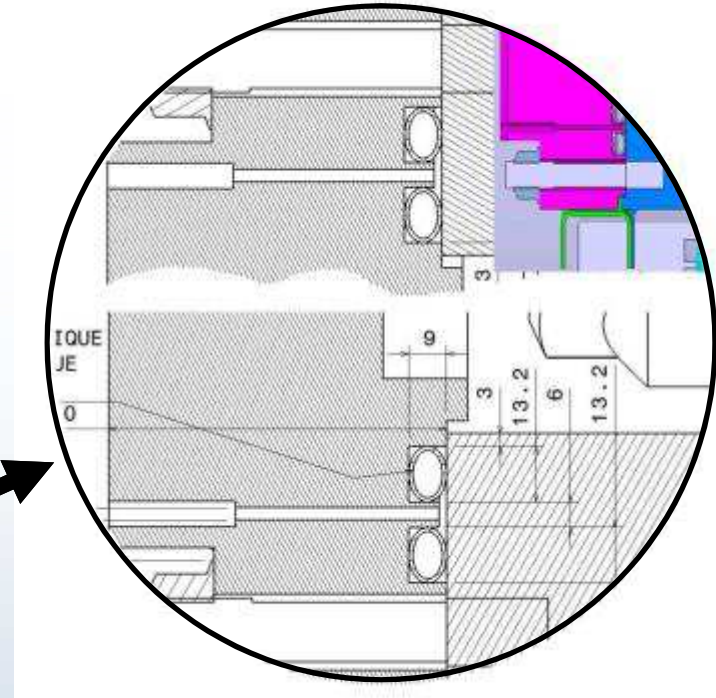
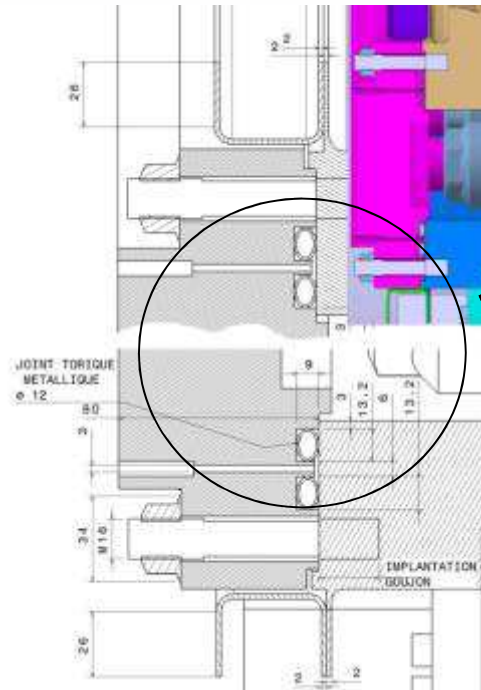
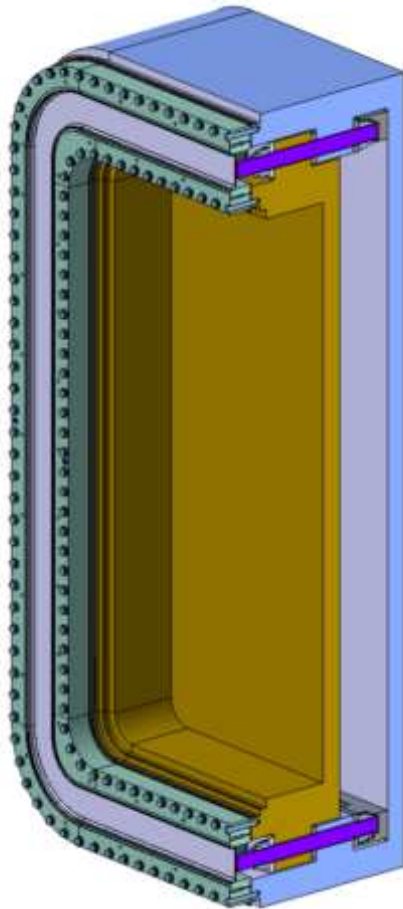



# PARTICLE ACCELERATOR: UHV

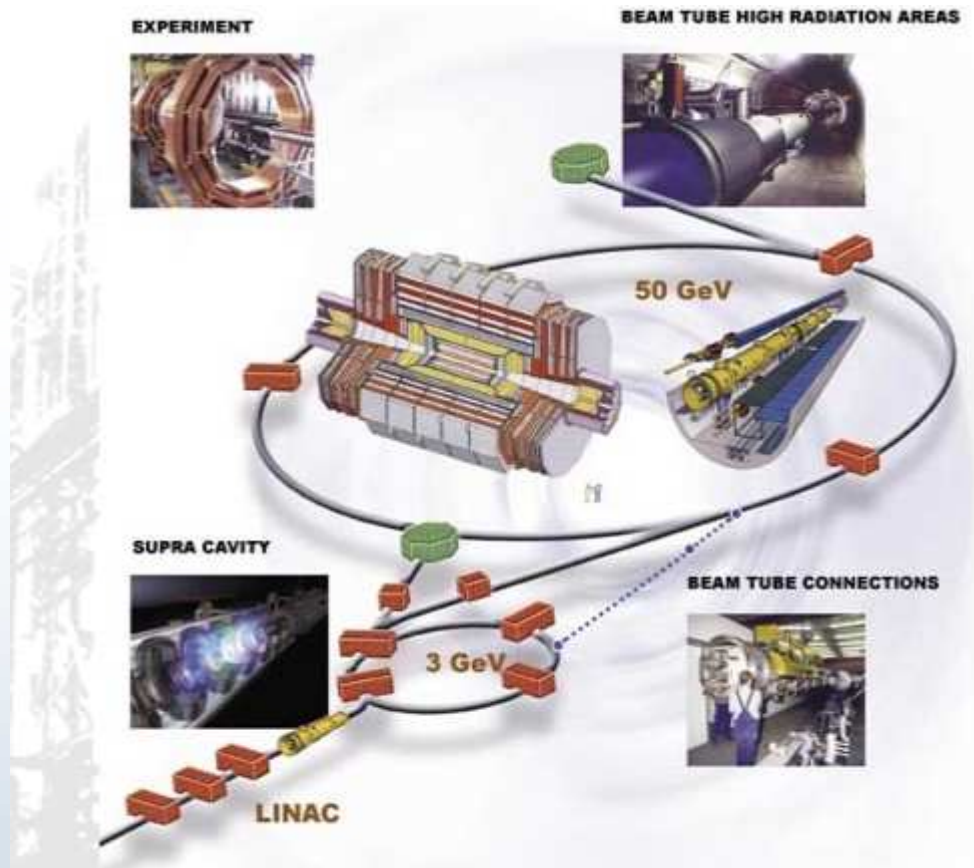

## Main projects

- CERN LHC (Switzerland)
- B-Factory (Japan)
- J-Park (Japan)
- DESY, GSI, FAIR (Germany)
- US Universities



# Cycle of engineered solution – integrated cooperation

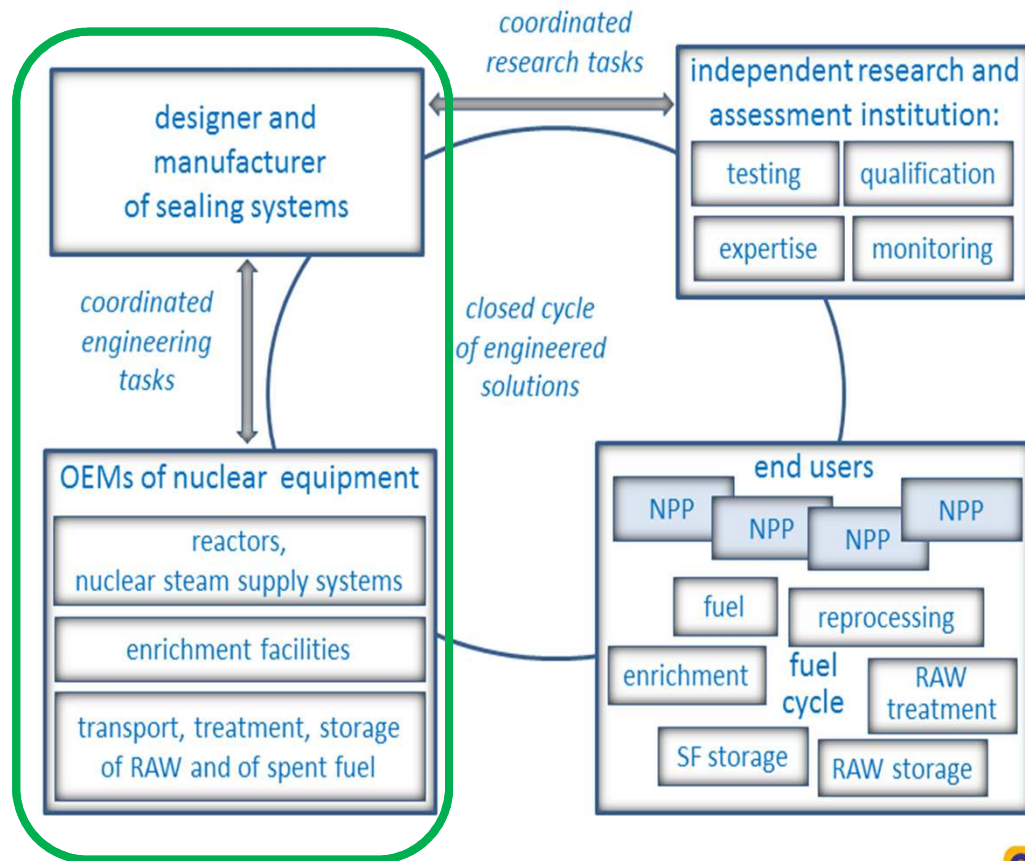

**solution design**  
by coordinated engineering tasks of

- specific skills
- specific know-how
- long-term experience
- communication and feedback over component / NPP lifetime

**design, test, manufacturing**  
**qualification of**

**sealing system + component**

**1 : 4**



# Contact

- Thomas J. Ritter  
Senior Market Manager, Nuclear & Land Based Turbines
- Email: [thomas.ritter@techneticsgroup.com](mailto:thomas.ritter@techneticsgroup.com)
- Tel: +49-6151-41222
- Tel: +1-803-695-3553
- Web: [www.techneticsgroup.com](http://www.techneticsgroup.com)

**THANK YOU FOR YOUR ATTENTION !**

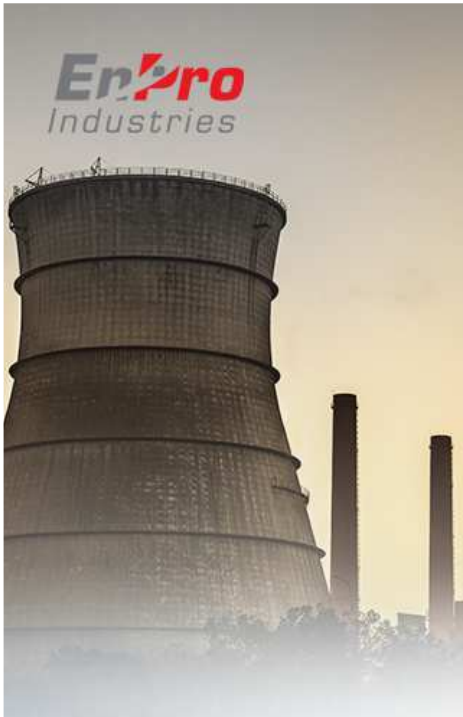

## Appendix

Appendix

ENGINEERED SOLUTIONS FOR DEMANDING ENVIRONMENTS®

**Technetics**  
GROUP

EnPro Industries companies

**EN • KO**  
2014

# Recent Publications

- **Inžinieringové riešenia pre tesnenia v jadrovej energetike (SK)**  
<http://www.energia.sk/tema/bezpecnost-a-efektivnost/inzinieringove-riesenia-pre-tesnenia-v-jadrovej-energetike/11466/>
- **Desaťročia expertíz tesnení: od kvalifikovaného laboratória po celosvetovo uznávané laboratórium v jadrovom priemysle (SK)**  
<http://www.energia.sk/pr-sprava/bezpecnost-a-efektivnost/desatrocia-expertiz-tesneni-od-kvalifikovaneho-laboratoria-po-celosvetovo-uznavane-laboratorium-v-jadrovom-priemysle/11852/>
- **Statické tesnenia: koncept a technológie (SK)**  
<http://www.energia.sk/tema/bezpecnost-a-efektivnost/staticke-tesnenia-koncept-a-technologie/12659/>
- **Interview with René Gillier, Director Nuclear Strategic Business Unit (SK)**  
<http://www.energia.sk/rozhovor/bezpecnost-a-efektivnost/trufnemesi-utesnit-aj-vver/11978/>
- **Technetics Group / Technical Articles (EN):**  
<http://www.techneticsgroup.com/technical-information/technical-articles/>



# Technetics Group/CEA Maestral Laboratory

- Located in Pierrelatte, France
- Specialized lab for research and testing of nuclear seals in
  - Nuclear fuel enrichment technologies
  - NPP equipment and buildings
  - Nuclear waste handling technologies



# Technetics Group/CEA Maestral Laboratory

- Performance comparison tests

Kammprofil

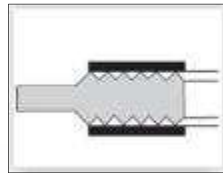

HELICOFLEX®



Spiral Wound  
Gasket (Flexitallic)

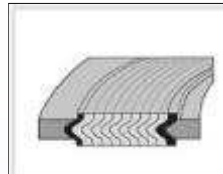

ORIGRAF®



- Criteria

- Amount of compression required to seal (bolt load) vs. specific sealing stress
- Amount of resiliency (in % of cross section and absolute in mm)
- Seal performance
  - leakage performance vs. steam and (potentially) other media
  - leakage performance vs. flange movement / flange rotation as result of impact to P & T, etc.
- Seal forgiving capabilities vs. condition of mating surfaces, such as aged mating surfaces, corroded mating surfaces, mechanical damages

# Sealing Application in Nuclear Fuel Enrichment Facilities

- **References**

- EURODIF, Pirelatte, France
- Nuclear Fuel reprocessing facility Le Hague, France
- AREVA U.S., Padukah, KY; USA, nuclear fuel enrichment facility (US DOE)
- Hanford site, Richland, WA, U.S.A.; (US DOE)
- SRS (Savannah River Site), GA, USA; (US DOE)
- US national labs, such as
  - Los Alamos, NM
  - Oak Ridge, TN
  - WEC Bettis National Nuclear Labs, PA



# PMUC Agreement (EDF)



## PMUC AGREEMENT (EDF)

### GARLOCK PRODUCTS PMUC APPROVED

- VITAFLEX spiral wound gaskets (n° 17171)
- ORIGRAF graphite expansé matricé (n° 17174)
- CEFIGRAF JPR graphite cut gaskets (n° 17280)
- GYLON 3500 modified PTFE cut gaskets (n° 17283)
- GYLON 3545 modified PTFE cut gaskets (*in process*)
- CEFIGRAF NS200 HP multi layer graphite sheets (n° 17189)

*(Helicoflex seals are not concerned by PMUC agreement because they are pure metallic)*





# Transportation & Storage Container Sealing for Spent Nuclear Fuel Rods

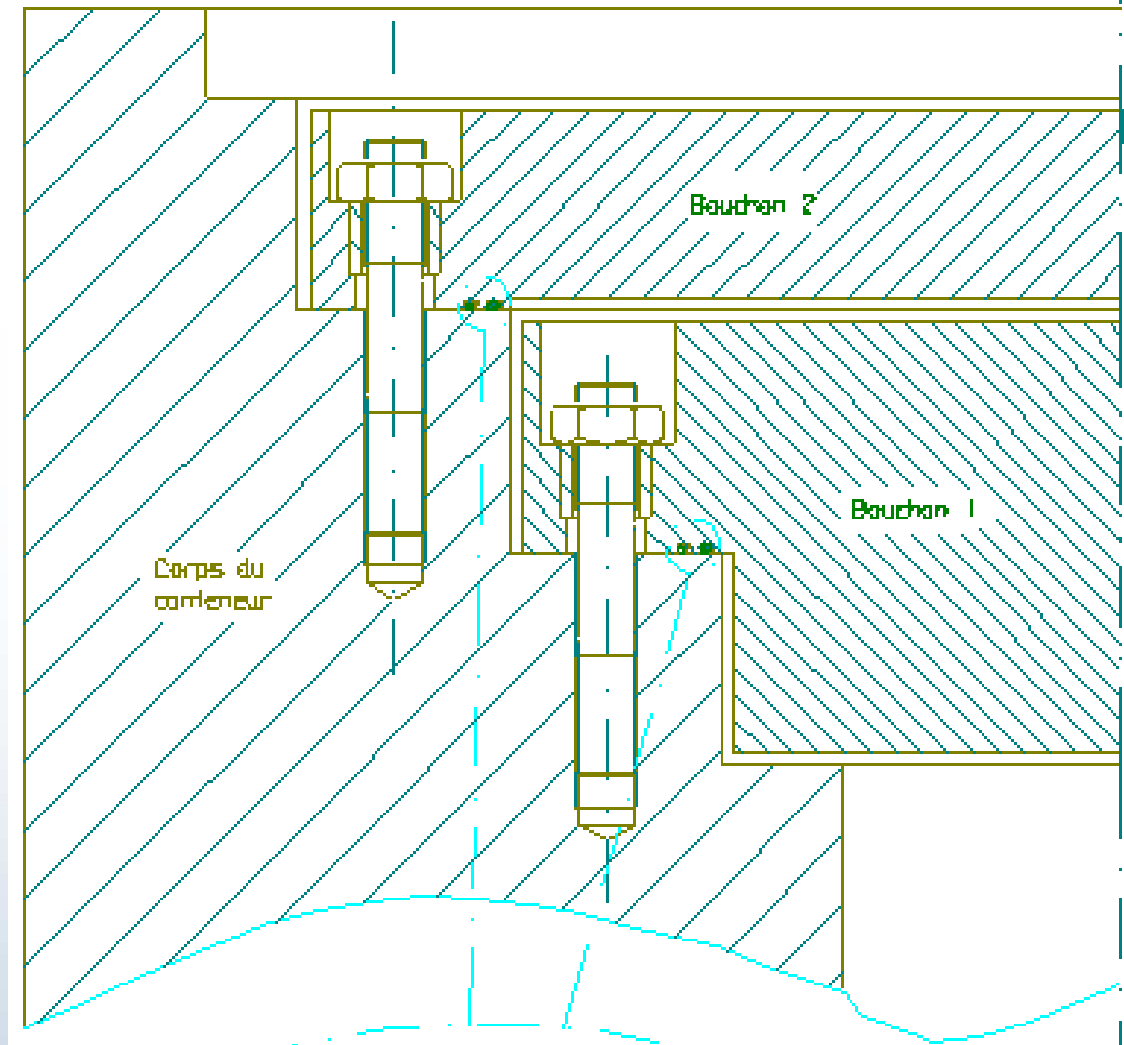
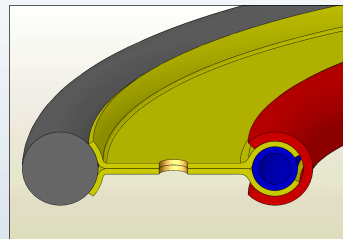
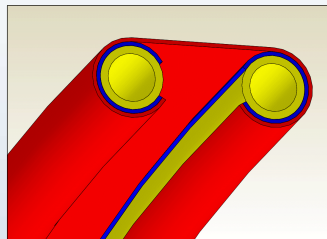
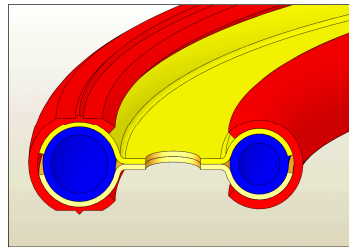

# Nuclear Spent Fuel Transportation & Storage Container

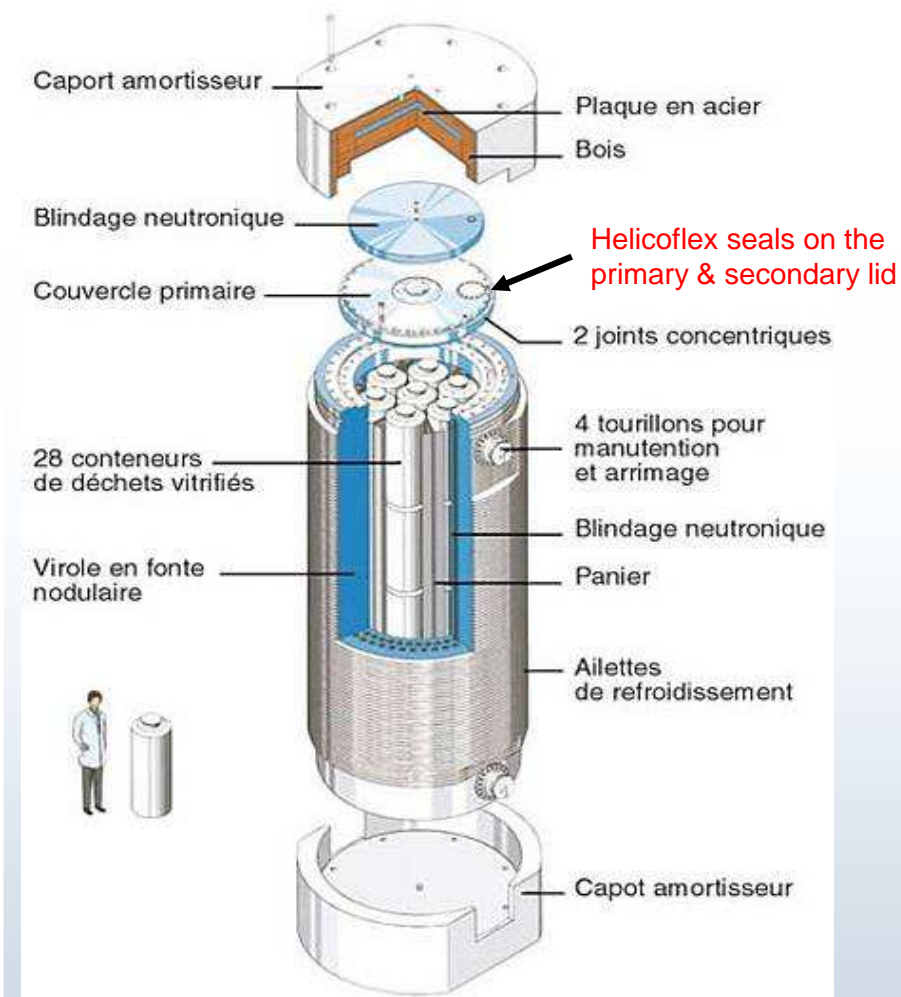

- **World's longest experience, largest reference in cask sealing technology and reputation**
- **Since 1977:** flanges & seals at the CEA / Pierrelatte Lab
- Aging qualification ongoing  
**120 years for Al / 150 years for Ag jacket** in cooperation
  - with **CEA** for aging
  - with **GNS** for temperature cycles
- **References:**
  - Areva TNI
  - Holtec
  - ENSA
  - GNS
  - Škoda JS (SRS, GNS... )
  - M.H.I. / HITACHI Zosen / KOBE Steel
  - TOSHIBA / MITSUI Zosen / O.C.L. / Doosan

# Sealing applications in transportation / storage container

## Points of touch

- Škoda JS – GNS:  
cooperation on CASTOR<sup>®</sup>440/84 containing TG seals
- Škoda JS – SRS,  
cask containing TG seals

# Reactor Pressure Vessel (RPV) Sealing

- Two designs available
  - HELICOFLEX®

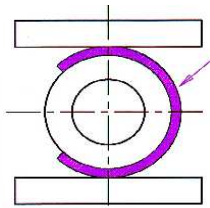

- Metal O-ring

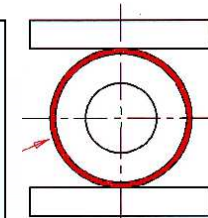

Technetics Group supplies RPV seals globally from US and French operations, global supplies.



# RPV O-Flex<sup>®</sup> Seals

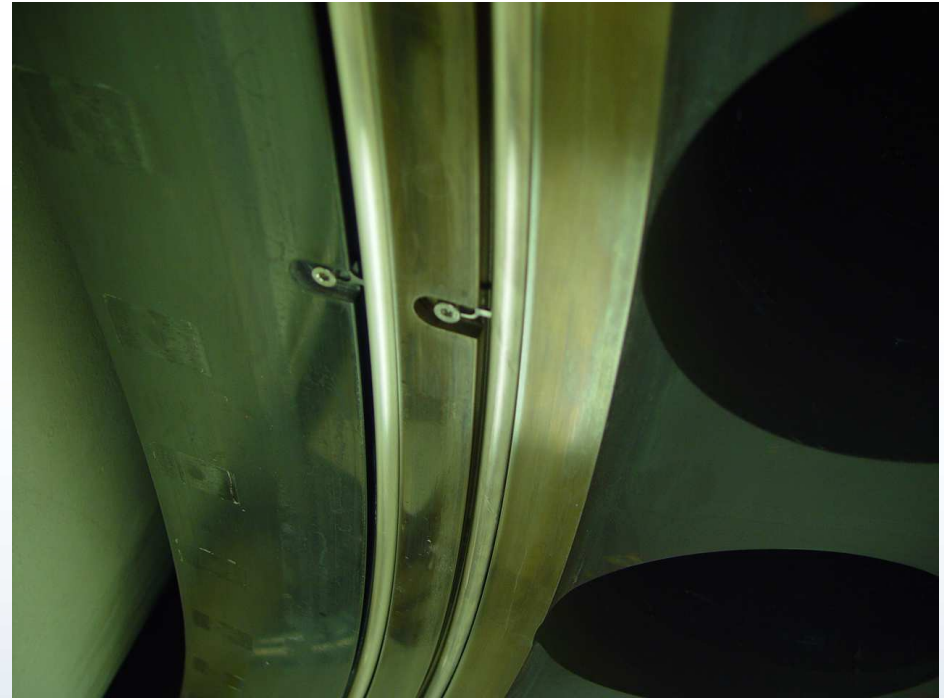
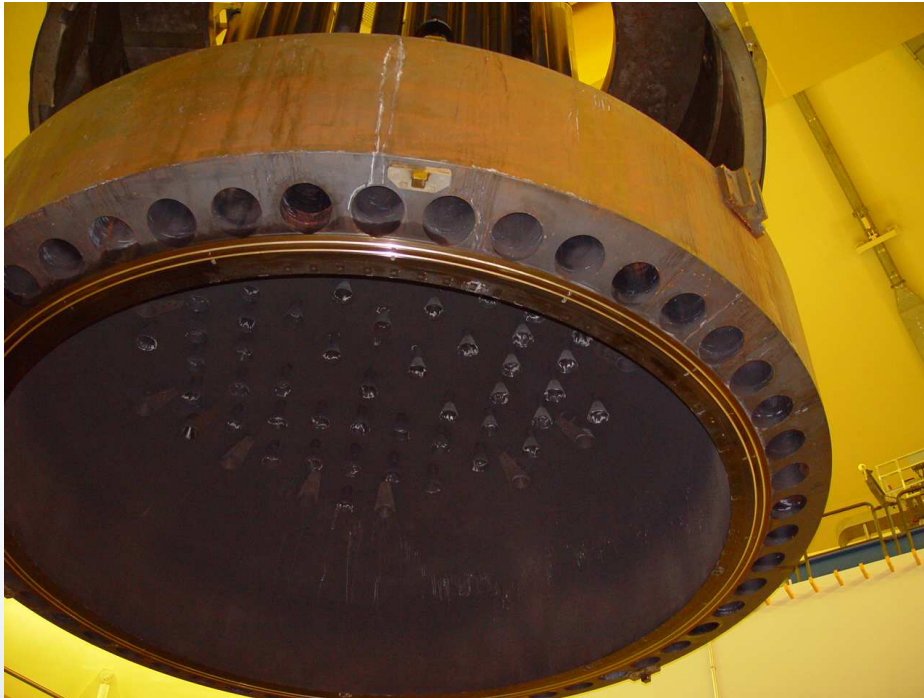

Generation III+ PWR: AP1000 (WEC), APR1400 (KEPCO), all SMR's (B&W; Holtec, WEC, GE-H)  
Generation III+ BWR: ABWR (IHI, BHK), ESBWR (GE-Hitachi)

# Helicoflex® RPV Seals

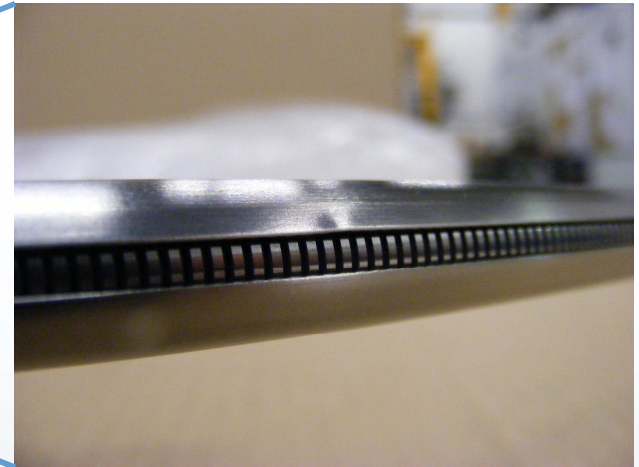

Generation III+ PWR: EPR (AREVA), ATMEA1 (AREVA – MHI), U.S.-APR1700 (MHI)

# Steam Generator / Pressurizer

- **Sealing of visit holes**
  - Manway, handholes, eyeholes
- **Sealing solutions**
  - Spiral wound gaskets (SWG) with controlled curve
    - Inconel / Graphite
  - ORIGRAF® graphite seals

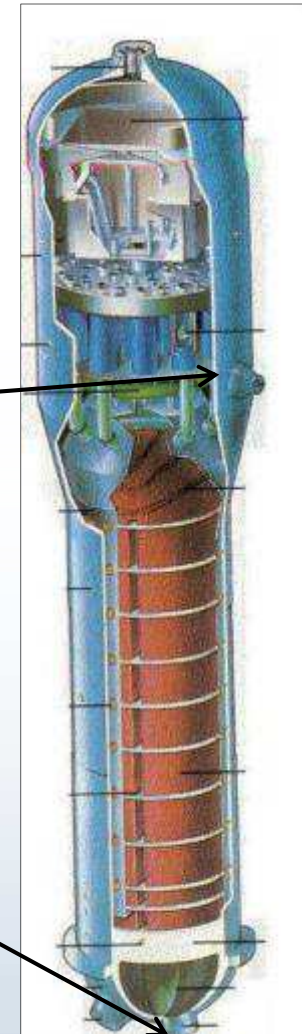



# Heat Exchanger

- **Sealing Solutions**

- Spiral wound gasket (SWG) with controlled curve
  - Inconel / Graphite
- ORIGRAF® graphite seals
- HELICOFLEX® seals

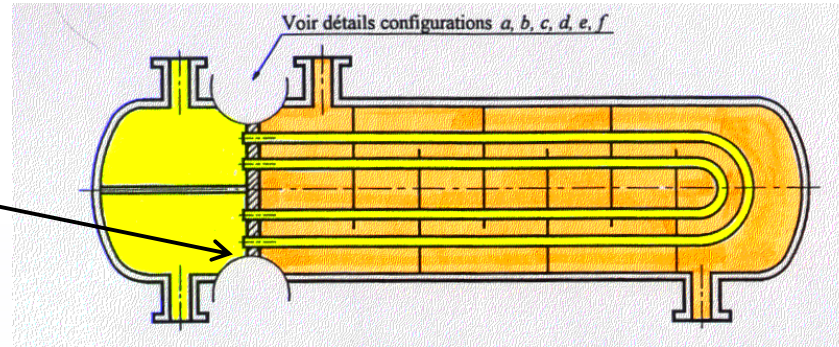

Sealing of tube sheet

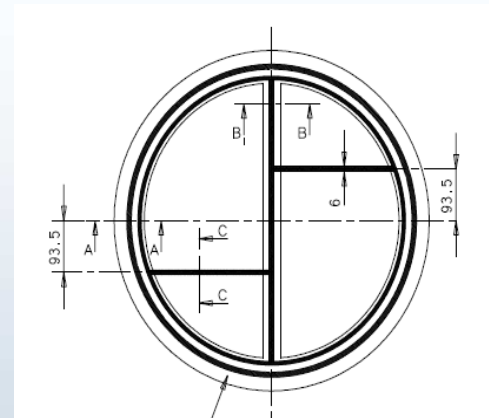



# Reactor Cooling Pumps

- **Sealing Solutions**
  - VITAFLEX® gaskets
    - Stainless steel / graphite
  - HELICOFLEX® seals

Sealing thermic barrier / upper part of the pump

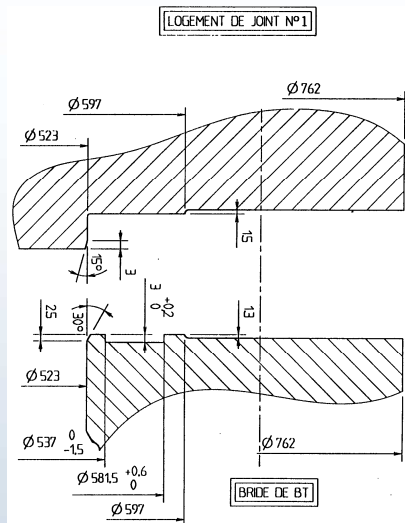

Sealing body of the pump / thermic barrier

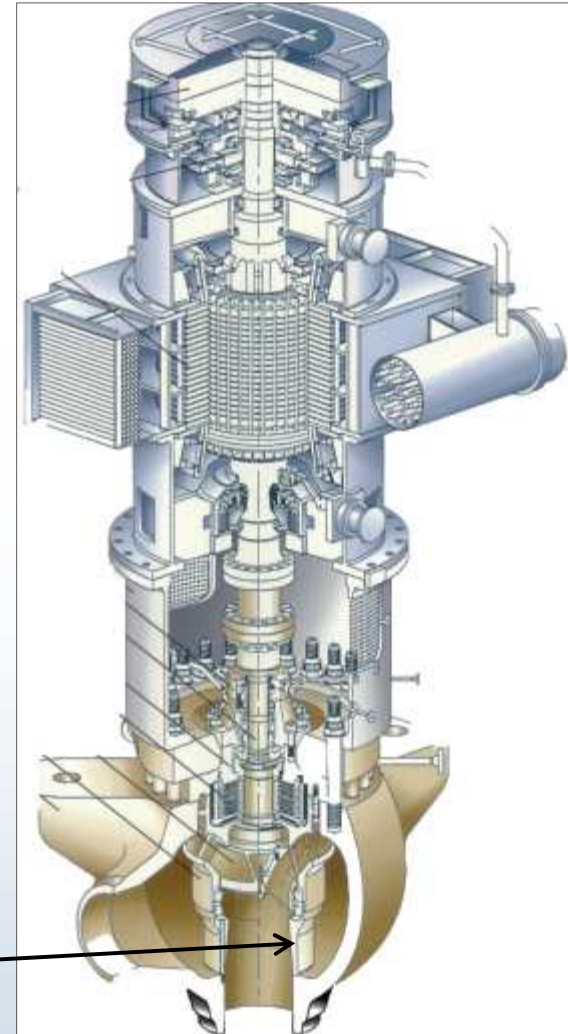
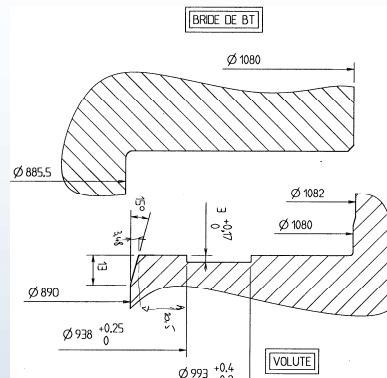

# Pipe Connections

- **Standard Option**
  - Spiral wound gasket (SWG)
- **Upgrade Solutions**
  - ORIGRAF® graphite gaskets
  - HELICOFLEX® HN208A seals (silver or SS lining)

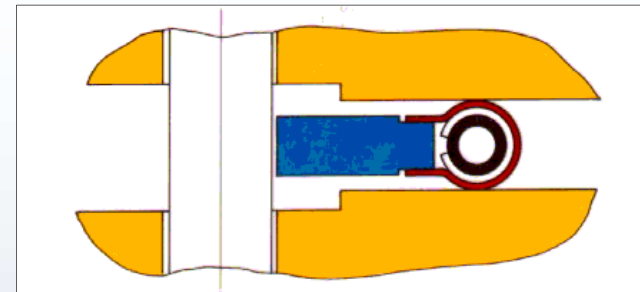
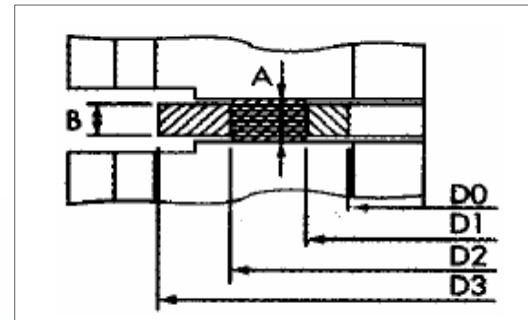

ANSI B16-5 flanges  
½" till 24"

# Pool Gates (Reactor & Fuel Buildings)

- **Inflatable Seals**
  - CEFIL'AIR and SBR (butadiene styrene) + static gasket



# Technetics Group: An EnPro Industries Company

consolidating expertise of  
engineered solutions for  
demanding environments®

**EnPro**  
Industries

Sealing Products

**Technetics**  
GROUP

**Garlock**  
SEALING TECHNOLOGIES\*

**STEMCO**  
A Higher Standard of Performance.™

Engineered Products

**GGB**  
BEARING TECHNOLOGY

**COMPRESSOR PRODUCTS**  
International

Engine Products & Services

**FAIRBANKS  
MORSE  
ENGINE**

NYSE: NPO \$73.63;  
Jan 29<sup>th</sup>, 2014

Revenue: \$1.5 B / 5,500 employees / 60 primary manufacturing locations



# Revenue by Market

